

1 DOOR OPENING IN CURTAINWALL

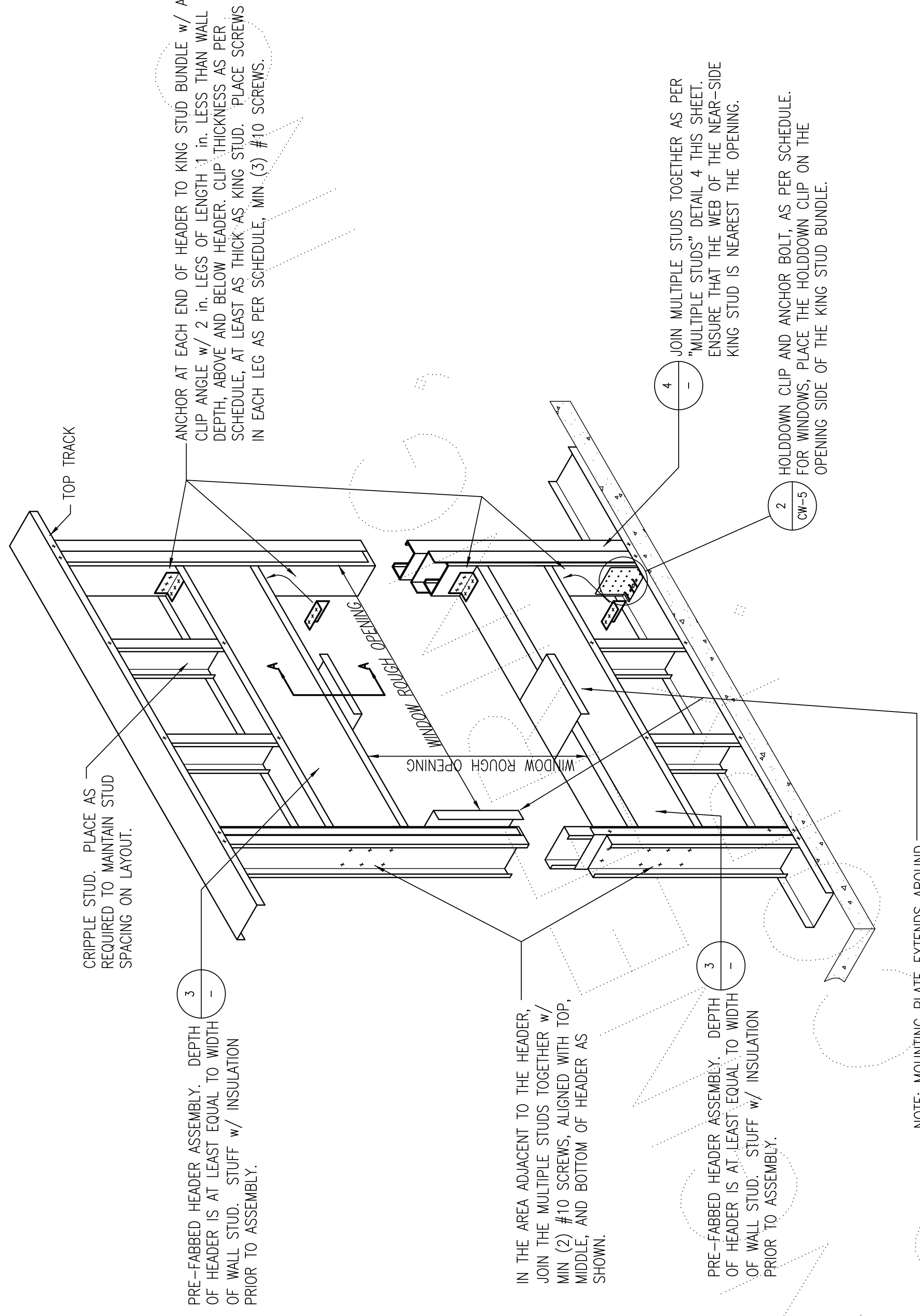

2 WINDOW OPENING IN CURTAINWALL

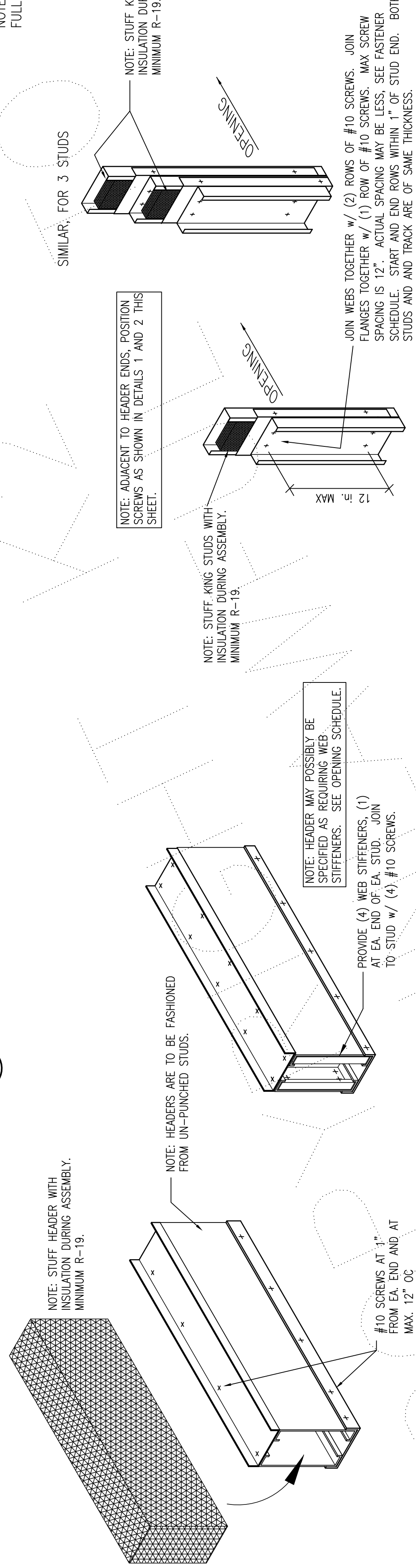

3 STANDARD PRE-FABBED BOX BEAM HEADER ASSEMBLY (WITH OR WITHOUT WEB STIFFENERS, PER SCHEDULE)

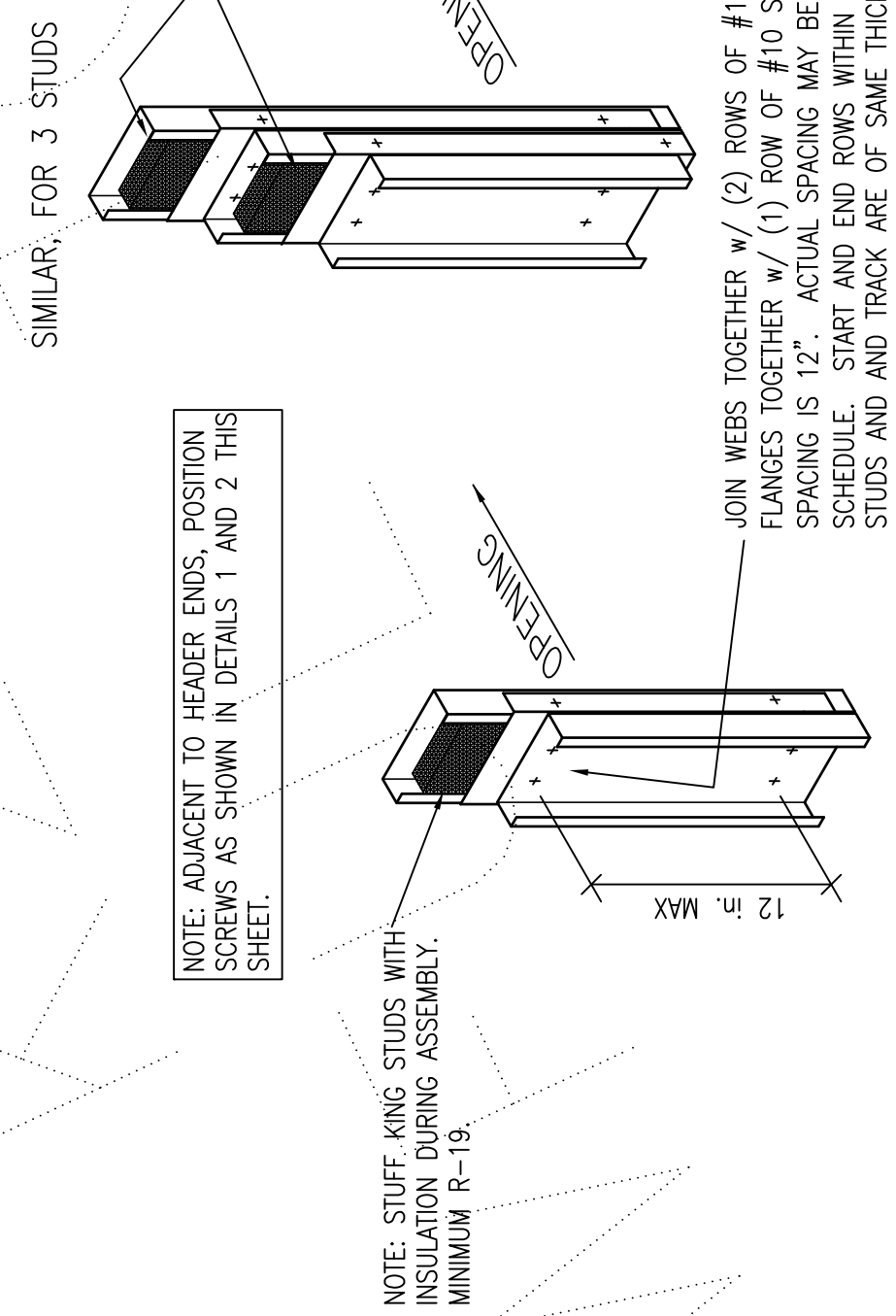

4 MULTIPLE STUDS

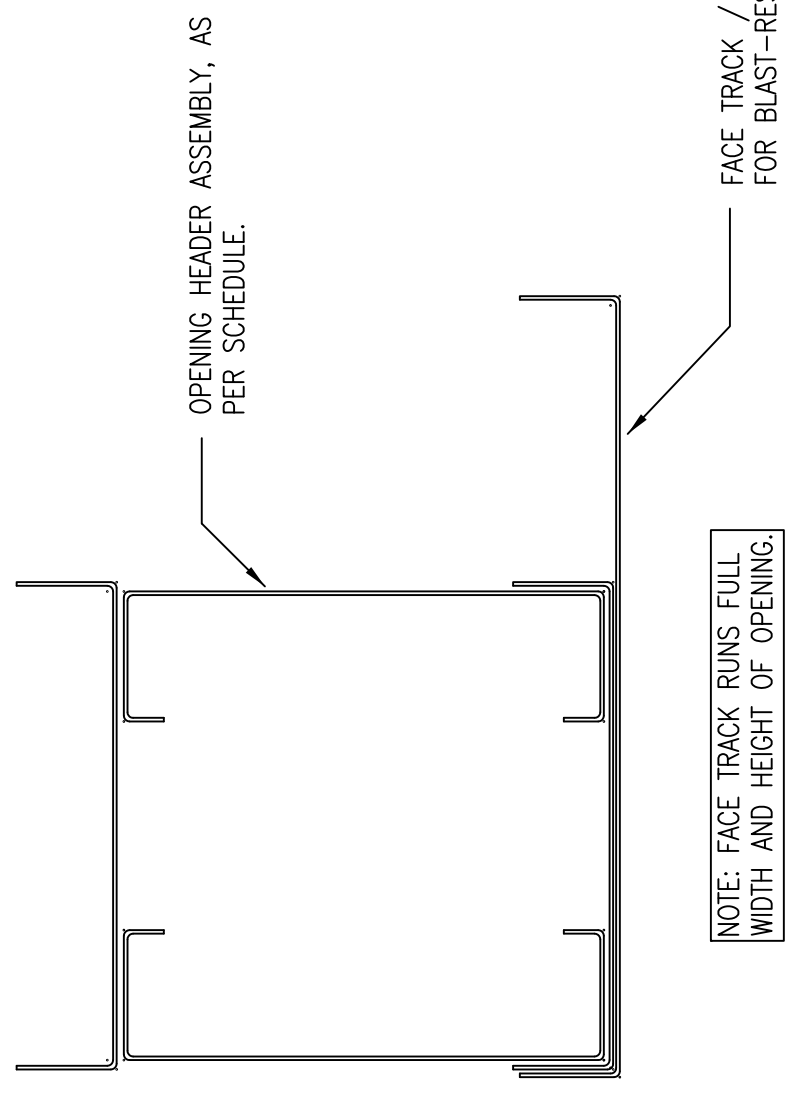

A-A CROSS SECTION - HEADER AND FACE TRACK

Consult: K2 Engineering, Inc. 5049 Van Hook Road, Henderson, NV 89015-3025
 N.J. # 15174, CA # 22556, SC # 19727, LA # 26140
 MS # 14183, TN # 112266, TX # 69462

Copyrighted. Unlawful to copy without permission. Print Shops: Please call (205) 951-3825 to receive a faxed authorization to print.

K2 Engineering, Inc.
 5049 Van Hook Road
 Henderson, NV 89015-3025
 Voice & Fax: (205) 951-3825

BLAST-RESISTANT OPENING FRAMING DETAILS

BY:	DATE:	CHK:	DATE:
JOB NO.	DWG. No.	BR-1	

© 1995-2010 All Rights Reserved
 These drawings are the property of K2 Engineering, Inc. and are not to be copied or reproduced in any manner without the express written consent of K2 Engineering, Inc. All rights are reserved. No part of these drawings and documents may be used or reproduced in any form without the express written consent of K2 Engineering, Inc. All rights are reserved.

BY:	
CHK:	
DATE:	