



K2 Engineering, Inc.

An Alabama Corporation

Robert P. Kiser, PE
President
5549 Hunter's Hill Road
Irondale, AL 35210-3036

Licensed in AL, GA, MS, SC, LA, TN, & FL
Voice & Fax: (205) 951-3825
e-mail: rkiser@k2engineeringinc.com
http://www.k2engineeringinc.com



ASCE 7-05 Wind Loads on Low Rise Curtainwall

References:

ASCE 7-05 "Minimum Design Loads for Buildings and Other Structures", Chapters 1 and 6

ProjectReference := "Example project Gardendale, AL"

ApplicationArea := "57' roof height 60' parapet height w/ 33-6 foot stud span to truss bottom"

Basic Wind Speed (3 second gust)	$V_w := 90$ (MPH)	As read from Figure 6-1
Wind Directionality Factor	$K_d := 0.85$	As defined in Table 6-4
Occupancy Category	OC := "III"	As defined in Table 1-1
Exposure Category	EC := "B"	As defined in Section 6.5.6.3
Topographic Factor	$K_{zt} := 1.0$	As defined in Figure 6-4 1.0 = flat terrain
Enclosure Classification	Enclosure := "ENCLOSED"	OPEN, PARTIAL, or ENCLOSED
Hurricane Prone Region?	Hurricane := "NO"	As defined in Section 6.2
Max Wall Height	$h := 60.0$ (ft)	
Building Length	Length := 250.0 (ft)	
Building Width	Width := 250.0 (ft)	
Stud Span	StudSpan := 33.5 (ft)	

Wall Cladding Effective Wind Area $WallEffWindArea := StudSpan \cdot \frac{StudSpan}{3}$

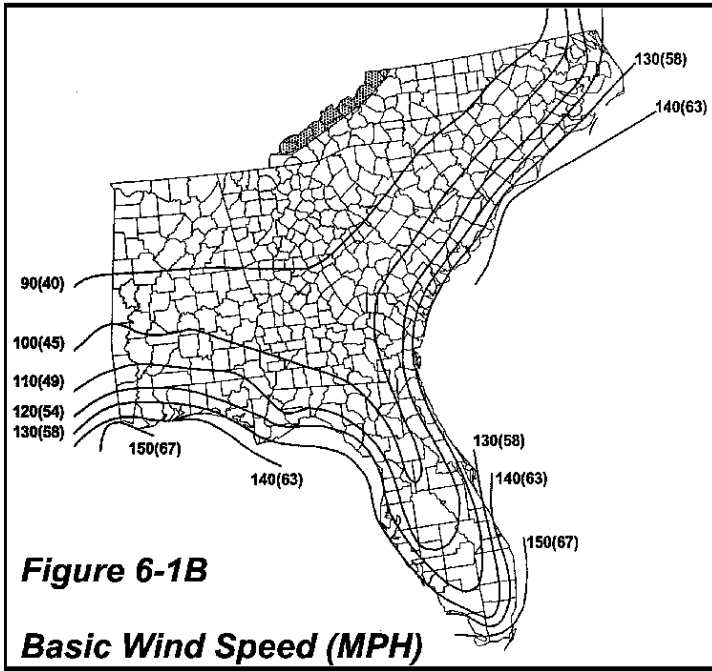

$WallEffWindArea = 374.08 \text{ (ft}^2\text{)}$

Effective Wind Area as per Definitions Section 6.2

Buildings are defined as Rigid Structures
Natural frequency > 1 Hz

Enclosed Building as per Definitions Section 6.2
Partially Enclosed Building as per Definitions Section 6.2

Find Wind Loads as per Section 6.5 "Method 2- Analytical Procedure"

Find dimension a as function of building dimensions

$L_{least} := \min(\text{Length}, \text{Width}) \quad a := \max(0.04 \cdot L_{least}, 3.0, \min(0.10 \cdot L_{least}, 0.4 \cdot h))$

$L_{least} = 250.00$

$a = 24.00 \text{ (ft)}$

Step 1 - Determine Basic Wind Speed V and Wind Directionality Factor Kd

V is taken from Figure 6-1, "Basic Wind Speed Map"

$V = 90.00 \text{ (MPH)}$

Kd is taken from Table 6-4, "Wind Directionality Factor"

$K_d = 0.85$

Step 2 - Determine the Importance Factor

Convert Roman Numerals into Zero-based Index into Matrix derived from Table 6-1

$OCIndex := (\text{if}(\text{OC} = \text{"I"} , 1, \text{if}(\text{OC} = \text{"II"} , 2, \text{if}(\text{OC} = \text{"III"} , 3, \text{if}(\text{OC} = \text{"IV"} , 4, 0))))$

$OCIndex = 3$

Category	Non-Hurricane Prone Regions and Hurricane Prone Regions with V = 85-100 mph and Alaska .	Hurricane Prone Regions with V > 100 mph
I	0.87	0.77
II	1.00	1.00
III	1.15	1.15
IV	1.15	1.15

Table 6-1

Table6_1 := $\begin{pmatrix} .87 & .77 \\ 1.0 & 1.0 \\ 1.15 & 1.15 \\ 1.15 & 1.15 \end{pmatrix}$

I := if[(V > 100 ∧ Hurricane = "YES"), Table6_1OCIndex-1, 1, Table6_1OCIndex-1, 0]

I = 1.15

Step 3 - Determine the Velocity Pressure Coefficient Kz

Exposure Categories are defined in Section 6.5.6.3 and values are defined in Table 6-3 using Case 1: "All Components & Cladding and MWFRS for Low-Rise Buildings"

	(0)	(.70)	(.85)	(1.03)	
	15	.70	.85	1.03	
	20	.70	.90	1.08	
	25	.70	.94	1.12	
	30	.70	.98	1.16	
	40	.76	1.04	1.22	
	50	.81	1.09	1.27	
	60	.85	1.13	1.31	
	70	.89	1.17	1.34	
	80	.93	1.21	1.38	
	90	.96	1.24	1.40	
KzHt :=	100	KzB := .99	KzC := 1.26	KzD := 1.43	
	120	1.04	1.31	1.48	
	140	1.09	1.36	1.52	
	160	1.13	1.39	1.55	
	180	1.17	1.43	1.58	
	200	1.20	1.46	1.61	Interpolate to find Kz value for each Exposure Category
	250	1.28	1.53	1.68	
	300	1.35	1.59	1.73	
	350	1.41	1.64	1.78	ValueKzB := linterp(KzHt, KzB, h)
	400	1.47	1.69	1.82	ValueKzC := linterp(KzHt, KzC, h)
	450	1.52	1.73	1.86	ValueKzD := linterp(KzHt, KzD, h)
	500	1.56	1.77	1.89	

Select appropriate Kzh value as per Input Exposure Category

$$K_{zh} := \text{if}(\text{EC} = \text{"B"}, \text{ValueKzB}, \text{if}(\text{EC} = \text{"C"}, \text{ValueKzC}, \text{ValueKzD})) \quad K_{zh} = 0.85$$

Step 4 - Determine the Topographic Factor Kzt

Per Section 6.5.7 and as defined in Figure 6-4, for flat local terrain: K_{zt} = 1.00

Step 5 - Determine the Gust Effect Factor

Note: gust Factor is not broken out separately for components and cladding.

Step 6 - Determine Enclosure Classification

Per Section 6.5.9 and as defined in Section 6.2: Enclosure = "ENCLOSED"

Step 7 - Determine Internal Pressure Coefficient GC_{pi}

Per Section 6.5.11.1 and as defined in Figure 6-5, with the Input Enclosure Specification:

$$GC_{piOpen} := 0.0 \quad GC_{piPartiallyEnclosed} := 0.55 \quad GC_{piEnclosed} := 0.18$$

$GC_{pi} = 0.18$

Step 8 - Determine External Pressure Coefficient GC_{pf} for each Wall Loading Zone

Handle Low Rise Wall Components & Cladding

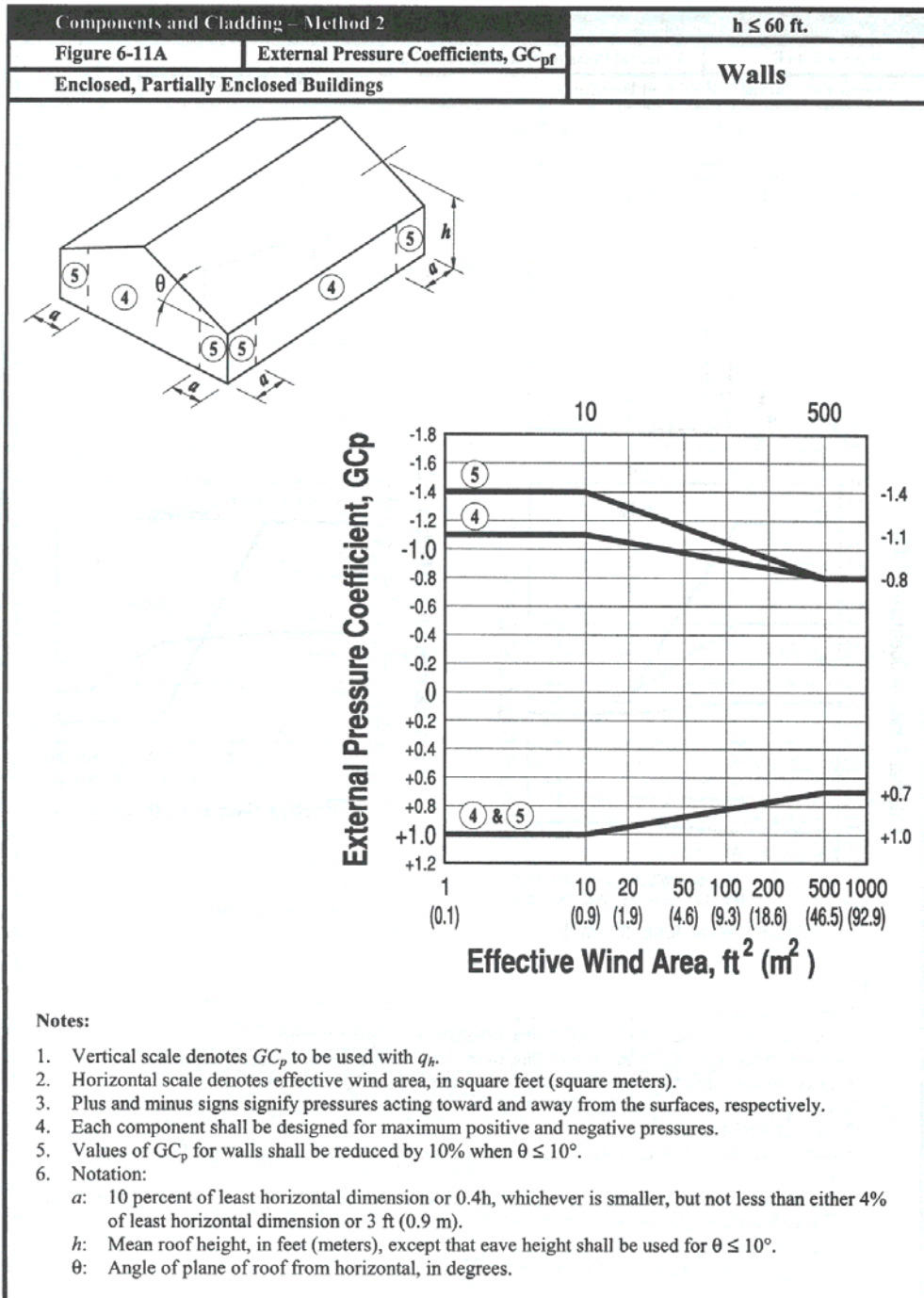

Per Section 6.5.11.2.2 and as defined in Figure 6-11A,B, with Input Effective Wind Area, find GC_{pf} for Low Rise Wall Components and Cladding.

Handle Low Rise Wall Components & Cladding

Note: the sloped part of the curve is determined by an logarithmic curve fit of the data in the graph.

$$\text{Value5Negative} := -1.753155 + 0.15337 \cdot \ln(\text{WallEffWindArea})$$

$$\text{Value4Negative} := -1.276577 + 0.07668 \cdot \ln(\text{WallEffWindArea})$$

$$\text{Value45Positive} := 1.176577 + -0.07668 \cdot \ln(\text{WallEffWindArea})$$

$$\text{WallCoeff4Negative} := \text{if}(\text{WallEffWindArea} \leq 10, -1.1, \text{if}(\text{WallEffWindArea} \geq 500, -0.8, \text{Value4Negative}))$$

$$\text{WallCoeff5Negative} := \text{if}(\text{WallEffWindArea} \leq 10, -1.4, \text{if}(\text{WallEffWindArea} \geq 500, -0.8, \text{Value5Negative}))$$

$$\text{WallCoeff45Positive} := \text{if}(\text{WallEffWindArea} \leq 10, 1.0, \text{if}(\text{WallEffWindArea} \geq 500, 0.7, \text{Value45Positive}))$$

$$\text{WallEffWindArea} = 374.08$$

$$\text{WallCoeff4Negative} = -0.82$$

$$\text{WallCoeff5Negative} = -0.84$$

$$\text{WallCoeff45Positive} = 0.72$$

Step 9 - Determine Velocity Pressure qh and q as function of height

$$K_{\text{zused}} := \text{if}(\text{EC} = \text{"B"}, K_{\text{zB}}, \text{if}(\text{EC} = \text{"C"}, K_{\text{zC}}, K_{\text{zD}}))$$

$$K_{\text{z15}} := \text{interp}(K_{\text{zHt}}, K_{\text{zused}}, 15)$$

$$Kz20 := \text{linterp}(KzHt, K_{zused}, 20)$$

$$Kz25 := \text{linterp}(KzHt, K_{zused}, 25)$$

$$Kz30 := \text{linterp}(KzHt, K_{zused}, 30)$$

$$Kz35 := \text{linterp}(KzHt, K_{zused}, 35)$$

$$Kz40 := \text{linterp}(KzHt, K_{zused}, 40)$$

$$Kz45 := \text{linterp}(KzHt, K_{zused}, 45)$$

$$Kz50 := \text{linterp}(KzHt, K_{zused}, 50)$$

$$Kz55 := \text{linterp}(KzHt, K_{zused}, 55)$$

$$Kz60 := \text{linterp}(KzHt, K_{zused}, 60)$$

As defined in Section 6.5.10:

$$q_h := 0.00256 \cdot K_{zh} \cdot K_{zt} \cdot K_d \cdot V^2 \cdot I \quad (\text{Equation 6-15})$$

$$q_h = 17.23 \quad (\text{psf})$$

$$q_{15} := 0.00256 \cdot Kz15 \cdot K_{zt} \cdot K_d \cdot V^2 \cdot I \quad q_{15} = 14.19 \quad (\text{all values in psf})$$

$$q_{20} := 0.00256 \cdot Kz20 \cdot K_{zt} \cdot K_d \cdot V^2 \cdot I \quad q_{20} = 14.19$$

$$q_{25} := 0.00256 \cdot Kz25 \cdot K_{zt} \cdot K_d \cdot V^2 \cdot I \quad q_{25} = 14.19$$

$$q_{30} := 0.00256 \cdot Kz30 \cdot K_{zt} \cdot K_d \cdot V^2 \cdot I \quad q_{30} = 14.19$$

$$q_{35} := 0.00256 \cdot Kz35 \cdot K_{zt} \cdot K_d \cdot V^2 \cdot I \quad q_{35} = 14.80$$

$$q_{40} := 0.00256 \cdot Kz40 \cdot K_{zt} \cdot K_d \cdot V^2 \cdot I \quad q_{40} = 15.40$$

$$q_{45} := 0.00256 \cdot Kz45 \cdot K_{zt} \cdot K_d \cdot V^2 \cdot I \quad q_{45} = 15.91$$

$$q_{50} := 0.00256 \cdot Kz50 \cdot K_{zt} \cdot K_d \cdot V^2 \cdot I \quad q_{50} = 16.42$$

$$q_{55} := 0.00256 \cdot Kz55 \cdot K_{zt} \cdot K_d \cdot V^2 \cdot I \quad q_{55} = 16.82$$

$$q_{60} := 0.00256 \cdot Kz60 \cdot K_{zt} \cdot K_d \cdot V^2 \cdot I \quad q_{60} = 17.23$$

Step 10 - Determine Design Wind Pressure for each Wall Cladding Surface Area

As defined in Section 6.5.12.4.1, the Design Wind Pressure p is:

$$p = q_h * (GC_p) - q_i(GC_{pi}) \quad \text{where } q_i \text{ can be taken as } q_h$$

q is taken as qz for windward walls
 q is taken as qh for leeward and side walls

Note that the Positive GCp values for Areas 4 and 5 are the same as per Figure 6-11A.

$$q_i := q_h$$

For Windward wall, all areas

$$p_{\text{Windward15Area4PosPos}} := q_{15} \cdot \text{WallCoeff45Positive} + q_i \cdot \text{GC}_{pi}$$

$$p_{\text{Windward20Area4PosPos}} := q_{20} \cdot \text{WallCoeff45Positive} + q_i \cdot \text{GC}_{pi}$$

$$p_{\text{Windward25Area4PosPos}} := q_{25} \cdot \text{WallCoeff45Positive} + q_i \cdot \text{GC}_{pi}$$

$$p_{\text{Windward30Area4PosPos}} := q_{30} \cdot \text{WallCoeff45Positive} + q_i \cdot \text{GC}_{pi}$$

$$p_{\text{Windward35Area4PosPos}} := q_{35} \cdot \text{WallCoeff45Positive} + q_i \cdot \text{GC}_{pi}$$

$$p_{\text{Windward40Area4PosPos}} := q_{40} \cdot \text{WallCoeff45Positive} + q_i \cdot \text{GC}_{pi}$$

$$p_{\text{Windward45Area4PosPos}} := q_{45} \cdot \text{WallCoeff45Positive} + q_i \cdot \text{GC}_{pi}$$

$$p_{\text{Windward50Area4PosPos}} := q_{50} \cdot \text{WallCoeff45Positive} + q_i \cdot \text{GC}_{pi}$$

$$p_{\text{Windward55Area4PosPos}} := q_{55} \cdot \text{WallCoeff45Positive} + q_i \cdot \text{GC}_{pi}$$

$$p_{\text{Windward60Area4PosPos}} := q_{60} \cdot \text{WallCoeff45Positive} + q_i \cdot \text{GC}_{pi}$$

$$p_{\text{Windward15Area4PosNeg}} := q_{15} \cdot \text{WallCoeff45Positive} - q_i \cdot \text{GC}_{pi}$$

$$p_{\text{Windward20Area4PosNeg}} := q_{20} \cdot \text{WallCoeff45Positive} - q_i \cdot \text{GC}_{pi}$$

$$p_{\text{Windward25Area4PosNeg}} := q_{25} \cdot \text{WallCoeff45Positive} - q_i \cdot \text{GC}_{pi}$$

$$p_{\text{Windward30Area4PosNeg}} := q_{30} \cdot \text{WallCoeff45Positive} - q_i \cdot \text{GC}_{pi}$$

$$p_{\text{Windward35Area4PosNeg}} := q_{35} \cdot \text{WallCoeff45Positive} - q_i \cdot \text{GC}_{pi}$$

$$p_{\text{Windward40Area4PosNeg}} := q_{40} \cdot \text{WallCoeff45Positive} - q_i \cdot \text{GC}_{pi}$$

$$p_{\text{Windward45Area4PosNeg}} := q_{45} \cdot \text{WallCoeff45Positive} - q_i \cdot \text{GC}_{pi}$$

$$p_{\text{Windward50Area4PosNeg}} := q_{50} \cdot \text{WallCoeff45Positive} - q_i \cdot \text{GC}_{pi}$$

$$p_{\text{Windward55Area4PosNeg}} := q_{55} \cdot \text{WallCoeff45Positive} - q_i \cdot \text{GC}_{pi}$$

$$p_{\text{Windward60Area4PosNeg}} := q_{60} \cdot \text{WallCoeff45Positive} - q_i \cdot \text{GC}_{pi}$$

For Leeward and Side Walls

$$p_{\text{OtherArea4PosPos}} := q_h \cdot \text{WallCoeff45Positive} + q_i \cdot \text{GC}_{pi} \quad p_{\text{OtherArea4PosNeg}} := q_h \cdot \text{WallCoeff45Positive} - q_i \cdot \text{GC}_{pi}$$

$$p_{\text{OtherArea4NegPos}} := q_h \cdot \text{WallCoeff4Negative} + q_i \cdot \text{GC}_{pi} \quad p_{\text{OtherArea4NegNeg}} := q_h \cdot \text{WallCoeff4Negative} - q_i \cdot \text{GC}_{pi}$$

$$p_{\text{OtherArea5PosPos}} := q_h \cdot \text{WallCoeff45Positive} + q_i \cdot \text{GC}_{pi} \quad p_{\text{OtherArea5PosNeg}} := q_h \cdot \text{WallCoeff45Positive} - q_i \cdot \text{GC}_{pi}$$

$$p_{\text{OtherArea5NegPos}} := q_h \cdot \text{WallCoeff5Negative} + q_i \cdot \text{GC}_{pi} \quad p_{\text{OtherArea5NegNeg}} := q_h \cdot \text{WallCoeff5Negative} - q_i \cdot \text{GC}_{pi}$$

$$p_{\text{OtherArea4PosPos}} = 15.55$$

$$p_{\text{OtherArea4PosNeg}} = 9.34$$

$$p_{\text{OtherArea4NegPos}} = -11.07$$

$$p_{\text{OtherArea4NegNeg}} = -17.27$$

$$p_{\text{OtherArea5PosPos}} = 15.55$$

$$p_{\text{OtherArea5PosNeg}} = 9.34$$

$$p_{\text{OtherArea5NegPos}} = -11.45$$

$$p_{\text{OtherArea5NegNeg}} = -17.65$$



K2 Engineering, Inc.

An Alabama Corporation

Robert P. Kiser, PE
 President
 5549 Hunter's Hill Road
 Irondale, AL 35210-3036

Licensed in AL, GA, MS, SC, LA, TN, & FL
 Voice & Fax: (205) 951-3825
 e-mail: rkiser@k2engineeringinc.com
 http://www.k2engineeringinc.com



ASCE 7-05 Wind Loads on Low-Rise Curtainwall

Input Values

ProjectReference = "Example project"	Gardendale, AL"
ApplicationArea = "57' roof height 60' parapet height w/ 33-6 foot stud span to truss bottom"	
Basic Wind Speed (3 second gust)	V = 90 (MPH) As read from Figure 6-1
Wind Directionality Factor	K _d = 0.85 As defined in Table 6-4
Occupancy Category	OC = "III" As defined in Table 1-1
Exposure Category	EC = "B" As defined in Section 6.5.6.3
Topographic Factor	K _{zt} = 1.00 As defined in Figure 6-4 1.0 = flat terrain
Enclosure Classification	Enclosure = "ENCLOSED" OPEN, PARTIAL, or ENCLOSED As defined in Section 6.2
Hurricane Prone Region?	Hurricane = "NO"
Building Length	Length = 250 (ft)
Building Width	Width = 250 (ft)
Max Wall Height	h = 60.0 (ft)
Stud Span	StudSpan = 33.50 (ft)
Wall Effective Wind Area	WallEffWindArea = 374.08 (ft ²)

Calculated Intermediate Values

Importance Factor	I = 1.15	As defined in Table 6-1
Velocity Pressure Coefficient	K _z h = 0.85	Interpolated from Table 6-3
Internal Pressure Coefficient	GC _{pi} = 0.18	As defined in Table 6-5
Velocity Pressure at Height h	q _h = 17.23 (psf)	Calculated per Equation 6-15
Dimension a	a = 24.00 (ft)	Width of end strip receiving elevated loads



K2 Engineering, Inc.

An Alabama Corporation

Robert P. Kiser, PE
 President
 5549 Hunter's Hill Road
 Irondale, AL 35210-3036

Licensed in AL, GA, MS, SC, LA, TN, & FL
 Voice & Fax: (205) 951-3825
 e-mail: rkiser@k2engineeringinc.com
 http://www.k2engineeringinc.com



ASCE 7-05 Wind Loads on Low-Rise Curtainwall

ProjectReference = "Example project"

Gardendale, AL"

ApplicationArea = "57' roof height 60' parapet height w/ 33-6 foot stud span to truss bottom"

Note: Pressures shown are "Components and Cladding" pressures.

Dimension a a = 24.00 (ft)

Building Surface	w/Positive Internal Pressure Coefficient (all values in psf)	w/ Negative Internal Pressure Coefficient (all values in psf)
------------------	---	--

Windward Wall, all areas

Elevation = 15 ft	pWindward15Area4PosPos = 13.35	pWindward15Area4PosNeg = 7.15
Elevation = 20 ft	pWindward20Area4PosPos = 13.35	pWindward20Area4PosNeg = 7.15
Elevation = 25 ft	pWindward25Area4PosPos = 13.35	pWindward25Area4PosNeg = 7.15
Elevation = 30 ft	pWindward30Area4PosPos = 13.35	pWindward30Area4PosNeg = 7.15
Elevation = 35 ft	pWindward35Area4PosPos = 13.79	pWindward35Area4PosNeg = 7.59
Elevation = 40 ft	pWindward40Area4PosPos = 14.23	pWindward40Area4PosNeg = 8.03
Elevation = 45 ft	pWindward45Area4PosPos = 14.59	pWindward45Area4PosNeg = 8.39
Elevation = 50 ft	pWindward50Area4PosPos = 14.96	pWindward50Area4PosNeg = 8.76
Elevation = 55 ft	pWindward55Area4PosPos = 15.25	pWindward55Area4PosNeg = 9.05
Elevation = 60 ft	pWindward60Area4PosPos = 15.55	pWindward60Area4PosNeg = 9.34

Leeward and Side Walls w/ Positive GCpi

Area 4 (Wall Interior)	pOtherArea4PosPos = 15.55	pOtherArea4PosNeg = 9.34
Area 5 (Wall Corners)	pOtherArea5PosPos = 15.55	pOtherArea5PosNeg = 9.34

Leeward and Side Walls w/ Negative GCpi

Area 4 (Wall Interior)	pOtherArea4NegPos = -11.07	pOtherArea4NegNeg = -17.27
Area 5 (Wall Corners)	pOtherArea5NegPos = -11.45	pOtherArea5NegNeg = -17.65